

# TRACE ELLIOT

## SERVICE MANUAL

**DATE :** December 29, 1999  
**Product Code:** N/A  
**Model Number :** Series 6 GP7- combos/head

Issued by:  
**Trace Elliot Limited**  
**Blackwater Trading Estate**  
**The Causeway**  
**Maldon**  
**Essex**  
**England**  
**CM4 4GG**

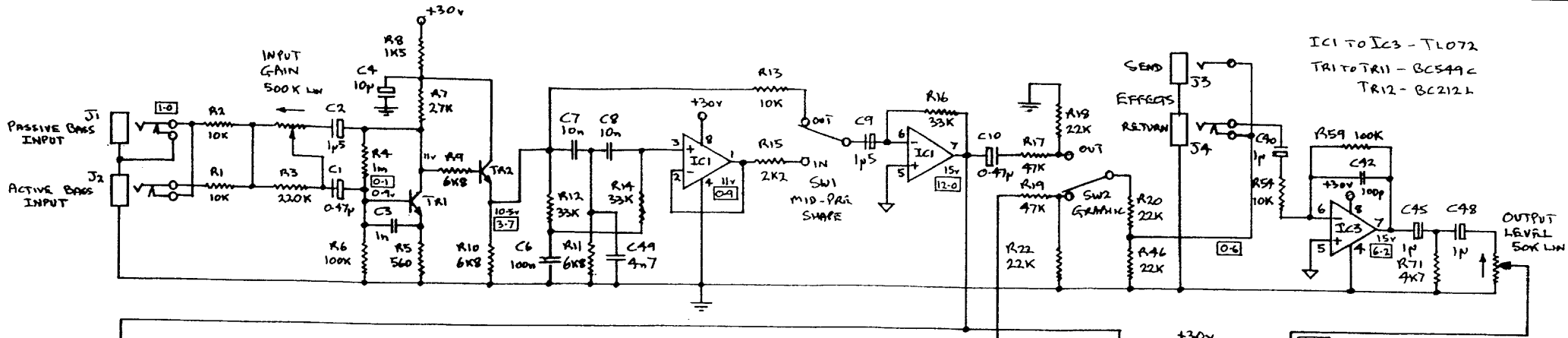

IC1 TO IC3 - TL072  
 TR1 TO TR11 - BC549C  
 TR12 - BC212L

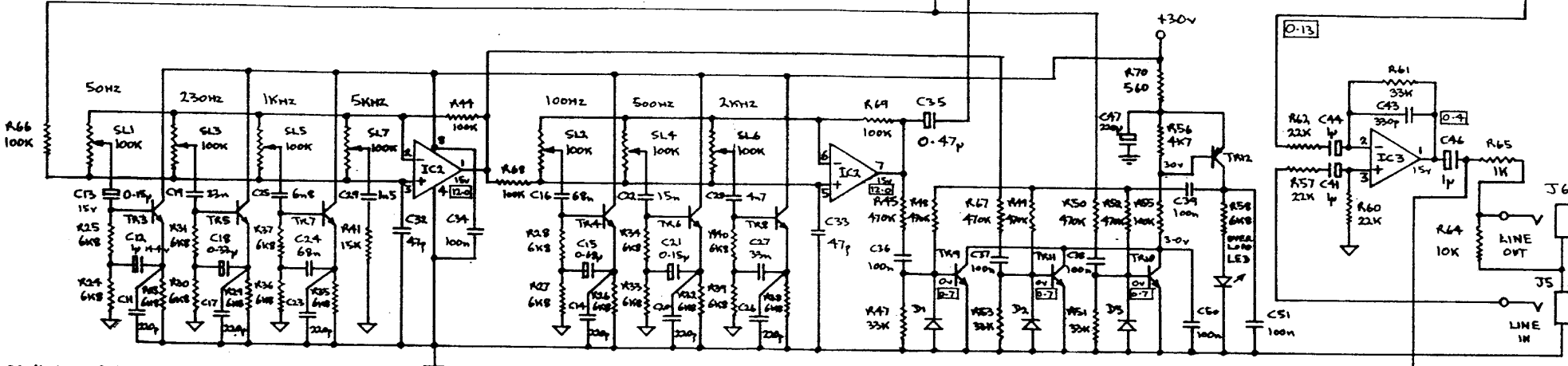

D.C. VOLTAGES MEASURED WITH NO SIGNAL INPUT.  
 SIGNAL VOLTAGES (IN BOXES) MEASURED WITH 1V P-P 1KHZ SINE WAVE INTO J1  
 INPUT GAIN SET TO 8 OUTPUT LEVEL SLT TO 1. GRAPHIC FLAT "IN"  
 MID "OUT". OUTPUT INTO 4Ω LOAD. ALL MEASUREMENTS ARE PK-PK.

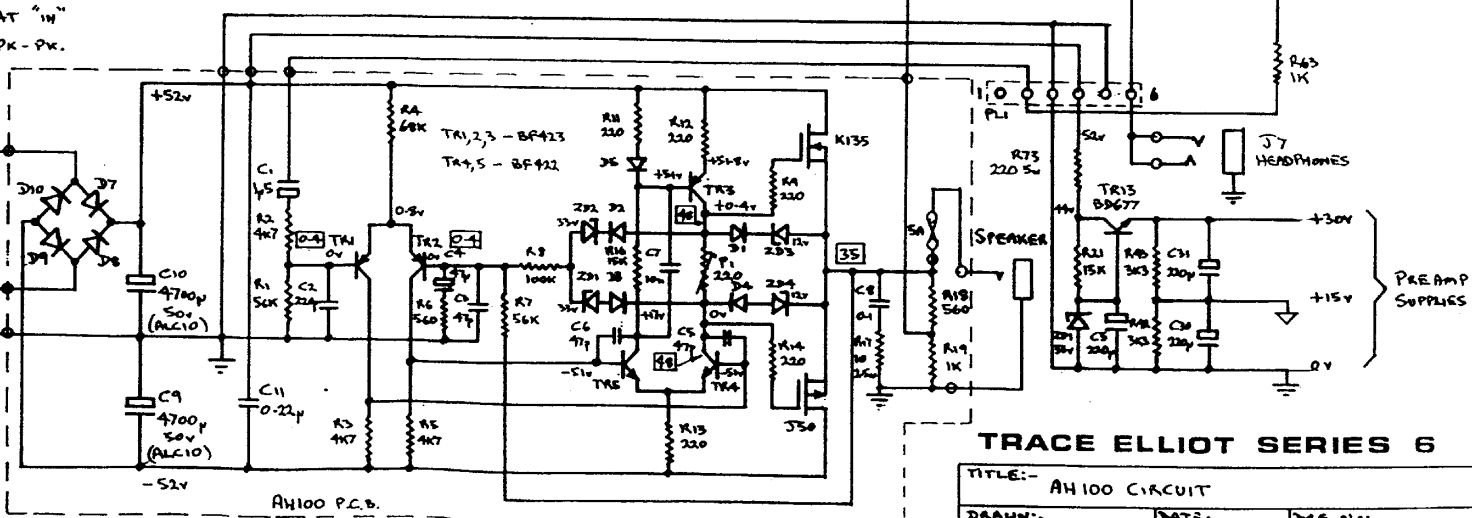
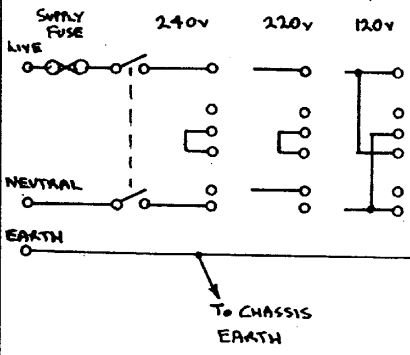

TRACE ELLIOT SERIES 6

TITLE:- AH100 CIRCUIT  
 DRAWN:- C. BUTTIN  
 DATE:- 23-11-88  
 DRA. NO:- AH100

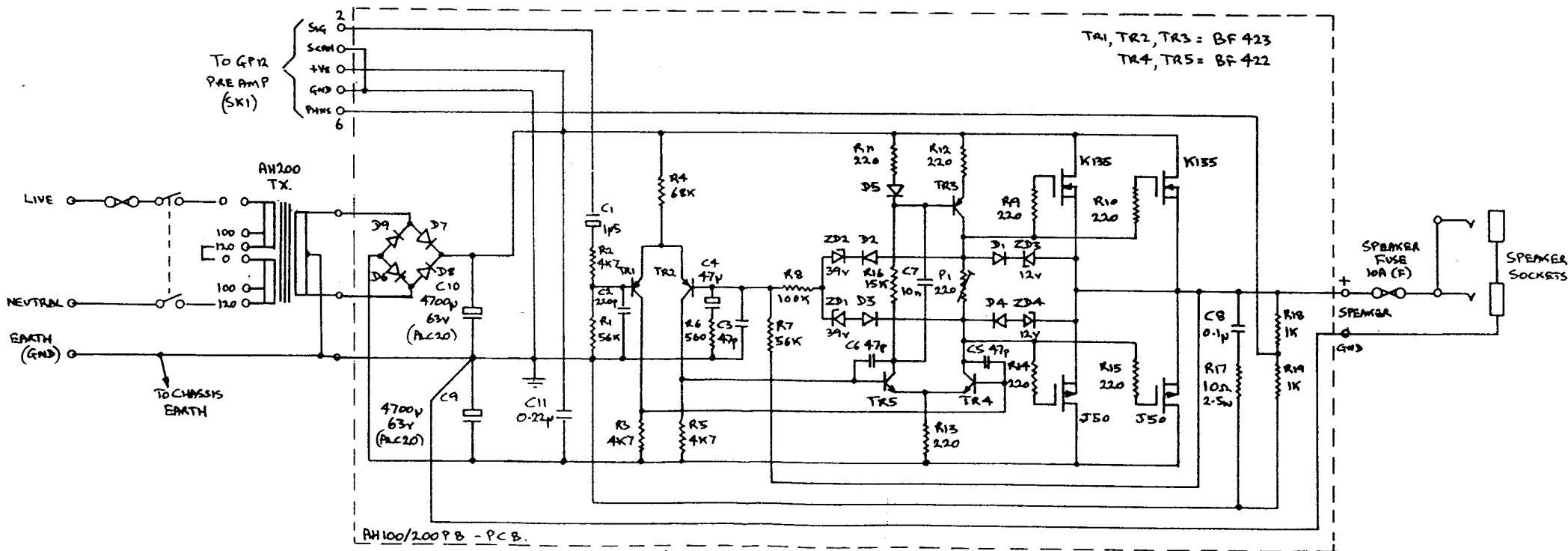

TRACE ELLIOT SERIES 6

TITLE: AH200 OUTPUT STAGE		
DRAWN: C. BUTSON	DATE: 6-2-89	DWG NO.: AH200



**SERVICE INFORMATION**

**GP7 MAIN BOARD – COMPONENT PARTS LIST**

REF	PART NUMBER	VALUE	REF	PART NUMBER	VALUE
R1	1610-RM10K	10K 1/4W MF	R61	1610-RM33K	33K 1/4W MF
R2	1610-RM10K	10K 1/4W MF	R62	1610-RM22K	22K 1/4W MF
R3	1610-RM220K	220K 1/4W MF	R63	1610-RM1K	1K 1/4W MF
R4	1610-RM1M	1M 1/4W MF	R64	1610-RM10K	10K 1/4W MF
R5	1610-RM560R	560R 1/4W MF	R65	1610-RM1K	1K 1/4W MF
R6	1610-RM100K	100K 1/4W MF	R66	1610-RM100K	100K 1/4W MF
R7	1610-RM27K	27K 1/4W MF	R67	1610-RM470K	470K 1/4W MF
R8	1610-RM1K5	1K5 1/4W MF	R68	1610-RM100K	100K 1/4W MF
R9	1610-RM6K8	6K8 1/4W MF	R69	1610-RM100K	100K 1/4W MF
R10	1610-RM6K8	6K8 1/4W MF	R70	1610-RM560R	560R 1/4W MF
R11	1610-RM6K8	6K8 1/4W MF	R71	1610-RM4K7	4K7 1/4W MF
R12	1610-RM33K	33K 1/4W MF	R72	1610-RM6K8	6K8 1/4W MF
R13	1610-RM10K	10K 1/4W MF	R73	1610-RM220R	220R 4W WW
R14	1610-RM33K	33K 1/4W MF	R74	1610-RM47K	47K 1/4W MF
R15	1610-RM2K2	2K2 1/4W MF	C1	1610-CO.47-35VT	0.47uF 35v T
R16	1610-RM33K	33K 1/4W MF	C2	1610-O1-35VT	1u5 35v T
R17	1610-RM47K	47K 1/4W MF	C3	1610-CIN-100VE	1nF 50v M
R18	1610-RM22K	22K 1/4W MF	C4	1610-C10-35VER	10uF 35v RE
R19	1610-RM47K	47K 1/4W MF	C5	1610-C220-35VER	220uF 35v RE
R20	1610-RM22K	22K 1/4W MF	C6	1610-C100N-100VE	100nF 50v M
R21	1610-RM10K	10K 1/4W MF	C7	1610-C10-100VE	10nF 50v M
R22	1610-RM22K	22K 1/4W MF	C8	1610-C10-100VE	10nF 50v M
R23	1610-RM6K8	6K8 1/4W MF	C9	1610-C1-35VT	1u5 35v T
R24	1610-RM6K8	6K8 1/4W MF	C10	1610-CO.47-35VT	0.47uF 35v T
R25	1610-RM6K8	6K8 1/4W MF	C11	1610-C220P-50VCD	220pF 50v DC
R26	1610-RM6K8	6K8 1/4W MF	C12	1610-C1-35VT	1uF 35v T
R27	1610-RM6K8	6K8 1/4W MF	C13	1610-CO.15-35VT	0.15uF 35v T
R28	1610-RM6K8	6K8 1/4W MF	C14	1610-C220P-50VCD	220pF 50v DC
R29	1610-RM6K8	6K8 1/4W MF	C15	1610-CO.68-35VT	0.68uF 35v T
R30	1610-RM6K8	6K8 1/4W MF	C16	1610-C68N-50VE	68nF 50v M
R31	1610-RM6K8	6K8 1/4W MF	C17	1610-C220P-50VCD	220pF 50v DC
R32	1610-RM6K8	6K8 1/4W MF	C18	1610-CO.33-35VT	0.33uF 35v T
R33	1610-RM6K8	6K8 1/4W MF	C19	1610-C33N-100VE	33nF 50v M
R34	1610-RM6K8	6K8 1/4W MF	C20	1610-C220CP-50VCD	220pF 50v DC
R35	1610-RM6K8	6K8 1/4W MF	C21	1610-CO.15-35VT	0.15uF 35v T
R36	1610-RM6K8	6K8 1/4W MF	C22	1610-C15N-100VE	15nF 50v M
R37	1610-RM6K8	6K8 1/4W MF	C23	1610-C22CP-50VCD	220pF 50v DC
R38	1610-RM6K8	6K8 1/4W MF	C24	1610-C68N-50VE	68nF 50v M
R39	1610-RM6K8	6K8 1/4W MF	C25	1610-C6N8-100VE	6n8 50v M
R40	1610-RM6K8	6K8 1/4W MF	C26	1610-C22CP-50VCD	220pF 50v DC
R41	1610-RM15K	15K 1/4W MF	C27	1610-C33N-100VE	33nF 50v M
R42	1610-RM3K3	3K3 1/4W MF	C28	1610-C4N7-100VE	4n7 50v M
R43	1610-RM3K3	3K3 1/4W MF	C29	1610-CIN-100VE	1n5 50v M
R44	1610-RM100K	100K 1/4W MF	C30	1610-C220-35VER	220uF 35v RE
R45	1610-RM470K	470K 1/4W MF	C31	1610-C220-35VER	220uF 35v RE
R46	1610-RM22K	22K 1/4W MF	C32	1610-C47P-50VCD	47pF 50v DC
R47	1610-RM33K	33K 1/4W MF	C33	1610-C47P-50VCD	47pF 50v DC
R48	1610-RM470K	470K 1/4W MF	C34	1610-C100N-100VE	100nF 50v M
R49	1610-RM470K	470K 1/4W MF	C35	1610-CO.47-35VT	0.47uF 35v T
R50	1610-RM470K	470K 1/4W MF	C36	1610-C100N-100VE	100nF 50v M
R51	1610-RM33K	33K 1/4W MF	C37	1610-C100N-100VE	100nF 50v M
R52	1610-RM470K	470K 1/4W MF	C38	1610-C100N-100VE	100nF 50v M
R53	1610-RM33K	33K 1/4W MF	C39	1610-C100N-100VE	100nF 50v M
R54	1610-RM10K	10K 1/4W MF	C40	1610-C1-35VT	1uF 35v T
R55	1610-RM100K	100K 1/4W MF	C41	1610-C1-35VER	1uF 35v RE
R56	1610-RM4K7	4K7 1/4W MF	C42	1610-C100P-50VCD	100pF 50v DC
R57	1610-RM22K	22K 1/4W MF	C43	1610-C330P-50VCD	330pF 50v DC
R58	1610-RM6K8	6K8 1/4W MF	C44	1610-C1-35VER	1uF 35v RE
R59	1610-RM100K	100K 1/4W MF	C45	1610-C1-35VER	1uF 35v RE
R60	1610-RM22K	22K 1/4W MF			

# PARTS LIST FOR PB200 POWER MODULES

Description	Part Code	Qty	Where Used
RESISTORS			
100K ¼ WATT	72-RM100K	1	R8
15K ¼ WATT	72-RM15K	1	R16
220R ¼ WATT	72-RM220R	8	R9-15 R19
4K7 ¼ WATT	72-RM4K7	3	R2 R3 R5
560R ¼ WATT	72-RM560R	1	R6
56K ¼ WATT	72-RM56K	2	R1 R7
68K ¼ WATT	72-RM68K	1	R4
10R 2.5 WATT	72-RWW10R-2.5W	1	R17
1K 2W PLUGABLE	72-RWW1K	1	R18
CAPACITORS			
0.22µF 250V POLY BOX	72-C0.22-250VP	1	C11
1.5µF 35V TANT	72-C1.5-35VT	1	C1
100nF 250V POLY BOX	72-C100N-250VP	1	C8
10nF 100V MYLAR	72-C10N-100VE	1	C7
220pF 100V CER DISC	72-C220P-100VCD2	1	C2
47µF 63V RADIAL	72-C47-63VER	2	C4 C12
47pF 100V CER DISC	72-C47P-100VCD	3	C3 C5 C6
4700µF 80V RADIAL	72-CAP-470080V	2	C9 C10
SEMI-CONDUCTORS			
12V ZENER DIODE	72-D-BZX55C12V	2	ZD3 ZD4
39V ZENER DIODE	72-D-BZX55C39V	2	ZD1 ZD2
GI 751 DIODE	72-D-GI751	4	D6-9
IN4148 DIODE	72-D-IN4148	5	D1-5
BUZ900 MOSFET	72-MOS-BUZ900	2	
BUZ905 MOSFET	72-MOS-BUZ905	2	
BF422 TRANSISTOR	72-TBF422	2	TR4 TR5
BF423 TRANSISTOR	72-TBF423	3	TR1-3
OTHERS			
ISOLATION BUSH	72-MOS-BUSH-WHT	8	
ISOLATION PAD	72-MOS-KOOL-PAD	4	
220R PRESET POT	72-PRESET-220R	1	P1
MAIN HEATSINK	71-HS-L200	1	

Rik Daniels  
April 3, 1997



**SERVICE INFORMATION**

GP7/1

## GP7 PREAMPLIFIER

The **GP7** preamplifier is used in the following **Trace Elliot Series 6** products:

Amplifier Heads: AH100

Combo amplifiers: 715

### TECHNICAL SPECIFICATIONS

Inputs	Passive Bass	Impedance 100k Ohms Input Range 50mV to 10V (peak-peak)
	Active Bass	Impedance 10k Ohms Input Range 100mV to 20V (peak-peak)
	Effects Return	Impedance 50k Ohms Nominal Input Level 0dBv (0.775v RMS)
	Line Input	Impedance 50k Ohms Nominal Input Level 0dBv
Outputs	Effects Send	Impedance 10k Ohms Nominal Level 0dBv
	Line Output	Impedance 600 Ohms Nominal Level 0dBv Maximum Level +9dBv (7v RMS)
Equalisation	Graphic	+/- 15dB at 7 centre frequencies
	Mid Pre Shape	+6dB at 50 Hz and 2kHz, -6dB at 400 Hz
Frequency Response		-3dB at 22 Hz and 25kHz
Signal/Noise Ratio		Better than 80dB (EQ flat, Mid out)
Distortion		Less than 0.05% THD



---

---

---

## SERVICE INFORMATION

GP7/2

## GP7 CIRCUIT DESCRIPTION

### INPUT J1/J2

J1 and J2 are the instrument inputs to the GP7. A signal entering J1 is passed to the first stage via R2 with R1 in parallel. A signal entering J2 is passed to the first stage via R1. This time however, R2 has one end connected to ground via the switched contact on J1. This provides a degree of attenuation to the "Active Bass" input J2, with the combination of R1 and R2 acting as a potential divider across the input.

### FIRST STAGE

The first stage is made up of transistors TR1 and TR2. TR2 is an "emitter follower" stage to provide a low impedance output to feed the next stage (the Mid Pre Shape circuit).

TR1 is the input gain/attenuation stage with its level controlled by the "Input Gain" pot. Gain is achieved by moving the pot's wiper toward the input end feeding more signal direct to TR1's base and the attenuation by moving the wiper to the opposite end, providing negative feedback from the collector to the base of TR1.

The supply to this first stage comes in via R8 and is decoupled with C4 to prevent any power supply noise from reaching this sensitive input circuit. C3 is to bypass any high frequency noise and prevent radio breakthrough, etc.

### MID PRE SHAPE

The combination of C6, C7, C8 and C49, along with resistors R11, R12 and R14 form a "Band Reject" filter. This provides a "Mid Cut" to signals passing through it. The filter is buffered by one half of IC1.

The "Mid Pre Shape" switch selects either the direct signal via R13 or the "Pre Shaped" signal via R15. These two resistors also set the gain of the following stage with a greater gain being provided by R15. R15's value has been chosen to provide the "Pre Shaped" sound with a "Top" and "Bottom" boost, as well as the "Mid" cut provided by the filter.

### THE GRAPHIC SECTION

The graphic equalisation section is configured around IC2. The input signal comes from the output of IC1 Pin 7 via R66 into the first half of the graphic. The graphic is split into two halves with the first half covering 4 frequency bands and the second half covering the remaining 3. The signal from the first half (IC2 Pin 1) is passed to the second half by resistor R68.

Each frequency band of the graphic is composed of one transistor, two capacitors and three resistors forming a resonant circuit (except for the 5kHz band that comprises of only C29 and R41). Taking the 2kHz band as an example, the transistor is TR8, the resistors are R38, R39 and R40 and the two frequency determining capacitors are C27 and C28.

This circuit presents a low impedance to the slider of the graphic pot SL6 at its 2kHz centre frequency. Thus, moving the slider down reduces the amount of signal at this frequency reaching Pin 3 of IC2 (the non-inverting input) producing a cut at 2kHz. Moving the slider up reduces the amount of negative feedback via R44 back into Pin 2 of IC2, increasing the gain at 2kHz, producing a boost.

The 220pF capacitor C26 is included to increase the stability of the resonant circuit. The two 47pF capacitors C32 and C33 help to prevent any high frequency oscillation or R.F. pick-up. The output of the graphic stage comes from IC2 Pin 7 and is fed back to the graphic "In/Out" switch. This selects either the direct signal out of Pin 7 of IC1 or the signal from the graphic.



---

---

---

## SERVICE INFORMATION

GP7/3

### EFFECTS SEND RETURN

The signal from the graphic "In/Out" switch is attenuated with resistors R20 and R46 to a suitable level for the "Effects Send" socket. Signals coming back into the "Effects Return" break Jack are passed through C90 and R54 to the first half of IC3. This stage has a gain of 10, set by R59 in order to return the signal back to "Line" level.

### OUTPUT STAGE

The signal from IC3 pin 7 is passed to the "Output Level" pot with C45, C48 and R71 forming a "High Pass" filter to set the low frequency roll off of the preamp output. The signal from the pot is passed to the second half of IC3. This feeds the "Line Out" socket as well as the signal to the PCB connector socket. The "Line Input" socket feeds into the non-inverting input Pin 3 of IC3 to be mixed with the preamp signal. C43 sets the high frequency limit of the output from the GP7 and R61 sets the gain of this final stage.

### SIGNAL LEVEL INDICATION

Transistors TR9, TR10 and TR11 are fed from three separate points throughout the GP7. These three transistors then combine to feed the "Overload LED". In this way, the level is monitored at all critical points in the GP7 to ensure that clipping or distortion cannot take place without the level indication circuit detecting and indicating the fact to the user with the "Overload" LED.

A sufficient level of positive signal on the base of one of these transistors will turn it on, pulling down its collector. This causes transistor TR12 to turn on via resistors R55 and R56 lighting the "Overload" LED. As TR12 turns on, its collector is taken to the full positive potential supplied by R70. This is passed via C39 and the three resistors R48, R49 and R52 back to the bases of the three transistors to keep them turned on. This will ensure that, even for the shortest overload spike, the "Overload" LED will light for a sufficient duration to be seen.

C47 decouples the supply to prevent spikes caused by the LED turning on from getting back into the supply rail. C50 and C51 help to slow down the fast turn on of TR12 to prevent the otherwise square wave interference from radiating to other parts of the circuit.

Diodes D1 to D3 clip off the negative part of the signal that is not used in the circuit.

### PREAMP SUPPLY REGULATION

The supply voltage comes into the GP7 PCB on connectors PL1 Pin 4. This is then dropped across R73 to a suitable level for the regulator transistor TR 13. C52 helps to smooth out any ripple on the incoming supply.

TR13 (the BD677) is working as a series regulator with its output voltage being set with a 33v zener diode in its base. The voltage across the zener is supplied by R21, and any noise being produced by the zener is decoupled by C83.

The output voltage from the regulator is dropped across the potential divider R42/R43 to provide a half supply reference to the op amps. C30 and C31 hold this voltage stable.